



**SIMPLE.**

**DURABLE.**

**EFFECTIVE.**

- Fuel Efficient 148 hp Tier III Cummins Engine
- Easy Transport with low overall height and weight
- Responsive Control System with smooth operation
- Excellent stability and maneuverability
- 9 Ton Load Capacity
- Excellent weight distribution for steep grades
- Low ground pressure to minimize ground disturbance



# 409 Forwarder

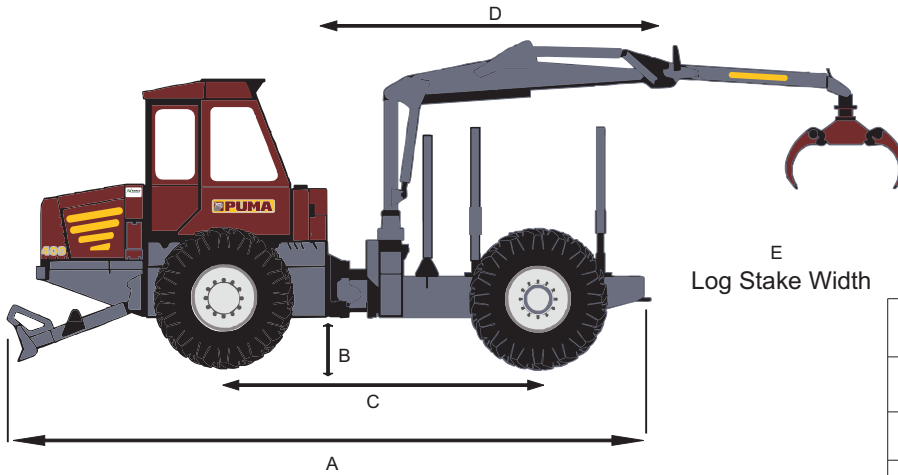

E  
Log Stake Width

A	Length	7264mm (286 in)
B	Ground Clearance	521mm (20.5 in)
C	Wheelbase	3658mm (144 in)
D	Bunk Length	2032mm (80 in)
E	Log Stake Width	2432MM (95.75 in)

## SPECIFICATIONS

**Gross Load Capacity:** 18,000 lbs  
**Gross Vehicle Weight:** 25,580 lbs  
**Ground Clearance:** 20.5"  
**Transportation Height:** 135"  
**Overall Width:** 105"  
**Fuel Tank:** 45 g  
**Tires:** 23.1 x 26 x 14ply  
**Optional:** 28L x 26 14ply  
**Engine:** 148 hp Cummins QSB4.5 Turbo-Charged After Cooled Diesel (Tier III)  
**Transmission:** Dana 24,000 Series (4 Speed) Powershift Transmission  
**Axles:** Dana Model 113  
 Front = 100% Diff. Lock  
 Rear = 40% Limited Slip  
**Brakes:** Internal West Disc Brakes, emergency and service, spring applied with hydraulic release

**Hydraulic System:** Power demand joystick controlled closed center system with Danfoss Plus+1 control system

**Electrical System:** 24 Volt

**Steering:** Joystick controlled oscillating knuckle with full oscillation lock, 40 degrees side to side articulation

**Loader:** Joystick controlled Kesla F500 crane with extendable boom and bypass grapple

**Cab:** Spacious tilting cab with deluxe seat and lighting, vent windows, circulation fan and heater with opt. air conditioning

### Options:

- Fire Suppression System
- Chains
- Bogie Tracks
- Xenon lighting
- 28" Wide Tires
- Aux. Heating Pro-Heat System for engine fuel / hydraulic tanks
- 

*SPECIFICATIONS SUBJECT TO CHANGE WITHOUT NOTICE*