

612 Forwarder



SIMPLE.

DURABLE.

EFFECTIVE.

- Fuel Efficient 197HP Tier III Volvo Engine
- Easy Transport with low overall height and weight
- Responsive Control System with smooth operation
- Excellent stability and maneuverability
- 12 Ton Load Capacity
- Excellent weight distribution for steep grades
- Low ground pressure to minimize ground disturbance



612 Forwarder

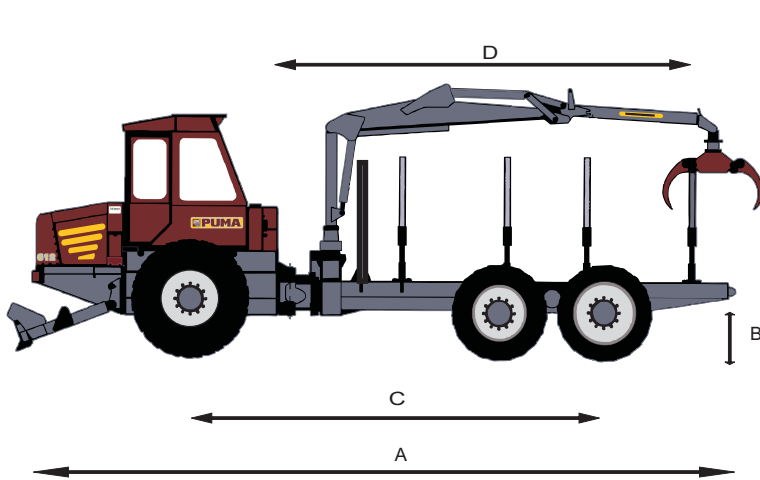

^E
Log Stake Width

A	Length	401
B	Ground Clearance	24"
C	Wheelbase	231"
D	Bunk Length	195"
E	Log Stake Width	91.5"

SPECIFICATIONS

Gross Load Capacity: 24,000 lbs
Gross Vehicle Weight: approx. 28,000 lbs
Ground Clearance: 24"
Transportation Height: 135"
Overall Width: 105"
Fuel Tank: 45 g
Tires: 23.1 x 26 x 16ply(Front)
 Optional: 28L x 26 16ply
Engine: 197HP TAD1252VE Tier III Volvo Engine
Transmission: Dana 24,000 Series (4 Speed)
 Powershift Transmission
Axles: Dana Model 113
 Front = 100% Diff. Lock
 Rear = Dana Model 151 Bogie, 45% Limited Slip
Brakes: Internal West Disc Brakes,
 emergency and service, spring applied with
 hydraulic release

Hydraulic System: Power demand joystick controlled closed center system with Danfoss Plus+1 control system

Electrical System: 24 Volt

Steering: Joystick controlled oscillating knuckle with full oscillation lock, 40 degrees side to side articulation

Loader: Joystick controlled Kesla F600 crane with extendable boom and bypass grapple

Cab: Spacious tilting cab with deluxe seat and lighting, vent windows, circulation fan and heater with opt. air conditioning

Options:

- Fire Suppression System
- Chains
- Xenon lighting
- 28" Wide Tires
- Aux. Heating Pro-Heat System for engine fuel / hydraulic tanks

SPECIFICATIONS SUBJECT TO CHANGE WITHOUT NOTICE